

# EFFICIENCY ANALYSIS OF A PHOTOVOLTAIC PLANT INTENDED TO SUPPLY ELECTRIC POWER TO AN INDUSTRIAL USER

## *ANALIZA EFICIENȚEI UNEI CENTRALE FOTOVOLTAICE DESTINATĂ FURNIZĂRII DE ENERGIE ELECTRICĂ UNUI UTILIZATOR INDUSTRIAL*

Mihai Dorel DAFINCA-IONESCU<sup>1</sup>

***Abstract:** Current concerns regarding the reduction of pollution generated by conventional energy sources, as well as the need to lower electricity costs, have led to the development of solutions that use renewable energy sources to supply industrial users with electricity through photovoltaic systems. Based on data collected over the course of one year, the paper includes an energy analysis of a photovoltaic system designed to supply electricity to a grid-connected industrial operator. The study highlights, for a real case, the contribution of the solar installation to covering the user's electricity demand and the economic benefits of the adopted solution.*

**Keywords:** Photovoltaic system, Energy delivered/injected/purchased from the public grid, smart meter.

***Rezumat:** Preocupările actuale privind reducerea poluării generate de sursele convenționale de energie, precum și necesitatea reducerii costurilor cu energia electrică, au condus la dezvoltarea de soluții care utilizează surse regenerabile de energie pentru alimentarea cu energie electrică a utilizatorilor industriali prin intermediul sistemelor fotovoltaice. Pe baza datelor colectate pe parcursul unui an, lucrarea include o analiză energetică a unui sistem fotovoltaic conceput pentru a furniza energie electrică unui operator industrial conectat la rețea. Studiul evidențiază, pentru un caz real, contribuția instalației solare la acoperirea cererii de energie electrică a utilizatorului și beneficiile economice ale soluției adoptate.*

---

<sup>1</sup> National University of Science and Technology Politehnica BUCHAREST, e-mail: [doru.dafinca@gmail.com](mailto:doru.dafinca@gmail.com)

**Cuvinte cheie:** Sistem fotovoltaic, Energie livrată/injectată/achiziționată din rețeaua publică, contor inteligent.

## 1. Introduction

The implementation of solar energy sources among industrial users has expanded significantly, driven by concerns regarding environmental pollution associated with the use of local energy sources, the need to reduce electricity bills, the availability of state subsidies, and the substantial decrease in photovoltaic panel prices.

To supply a small enterprise in the food industry with electrical energy, a photovoltaic system installed on the company's rooftop was proposed, intended to provide—together with the contribution from the public electricity grid—the enterprise's required energy demand [1]. The photovoltaic system was constrained by the available surface area for installing the panels.

The study presented in this paper aims to determine the extent to which the implemented system contributes to covering the enterprise's electricity needs, to assess its behavior over the course of one year, and to obtain data that would enable the energy manager to adopt effective measures for ensuring the required energy supply [2]. Measured data were analyzed to highlight the sustainability of the project. Additionally, a simulation was carried out in the MATLAB Simulink platform to provide a practical tool for comparing the enterprise's energy situation.

## 2. Characteristics of the analyzed user

The enterprise processes dairy products and is equipped primarily with the following electrical devices:

A tunnel and hearth oven, with an installed power of 18 kW and operating for 8 hours per day; A mixer, with an installed power of 14 kW and operating for 6 hours per day; A panna cotta inspection unit, with an installed power of 6 kW and operating for 8 hours per day; Other equipment, with a total installed power of 12 kW and operating for 8 hours per day.

Additionally, to supply the employees' electric vehicles, a 44 kW charging installation with two charging points was implemented and connected to the electrical network, operating on average 4 hours per day. The enterprise operates in a single shift and maintains production every day of the week. During periods of maximum solar irradiance, the solar panels generate

power exceeding the instantaneous demand; therefore, during these intervals, part of the photovoltaic production is consumed within the enterprise, while the surplus is fed into the public electricity grid.

The basic electrical diagram of the analyzed installation is shown in (Figure 1).

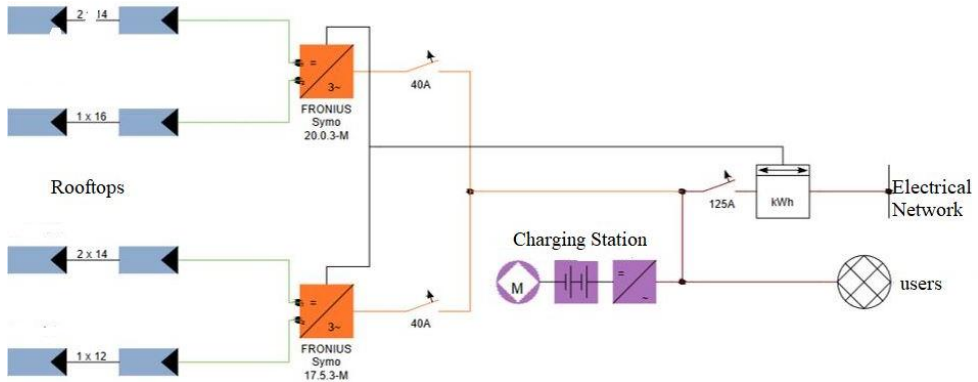

**Fig. 1.** Basic electrical diagram of the enterprise.

The solar power generation system includes 84 photovoltaic panels rated at 530–555 W, installed in two groups on the four production halls of the enterprise (Figure. 2). Each group of panels is connected to an inverter of 17.5 kW and 20 kW, respectively, both equipped with a monitoring system that records the total generated energy, the energy delivered to the enterprise, and the energy fed into the public electricity grid (Figure. 3).



**Fig. 2.** Placement of the photovoltaic panels on the production hall rooftops.

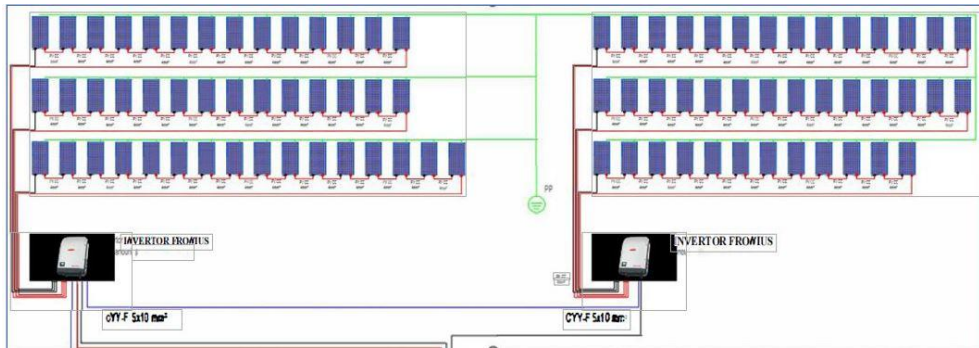

Fig. 3. Grouping of the photovoltaic panels.

### 3. Results of the experimental study

The data obtained from processing the information recorded by the two inverters over the course of one year are presented in Table 1 [3]. The data in Table 1 show that, over one year, approximately 46,3% of the energy generated by the solar installation is consumed within the enterprise, while about 52,56 is fed into the public electricity grid. The level of energy actually used within the enterprise depends on the solar irradiance level and the duration of sunlight during the day, on the production rate, and on the energy management of the two sources [4, 5].

Table 1. Summary of the data recorded over one year<sup>\*)</sup>

Month	Energy produced by the solar installation [kWh]	PV energy used in the factory [kWh]	Energy purchased from the electrical grid [kWh]	Energy used within the enterprise [kWh]	Energy fed into the electrical grid [kWh]	Ratio of generated energy to energy fed into the public grid [%]
1	2	3	4	5	6	7
April	5094,42	1746,68	5870,11	7616,79	3198,8	62,8
May	6550,63	1836,52	4745,78	6582,30	4640,4	70,8
June	6555,09	2037,67	4041,29	6078,96	4689,2	71,53
July	5799,44	2796,05	6230,53	9026,58	2913,29	50,23
August	5332,35	2586,12	4694,98	7281,10	2663,84	49,96
September	3061,96	1568,75	5718,98	7287,73	1448,41	47,3
October	2104,62	1650,86	5793,85	7444,71	440,15	20,91
November	883,13	802,97	7609,34	8412,31	77,76	8,8
December	523,44	473,91	8803,29	9277,20	48,04	9,18
January	1097,64	585,20	4645,82	5231,02	497,07	45,29
February	1582,83	1127,55	5644,07	6771,62	441,17	27,87

Table 1. (continued)

1	2	3	4	5	6	7
March	2757,76	2067,26	6159,28	8226,54	669,78	24,29
<b>TOTAL</b>	<b>41343,31</b>	<b>19279,52</b>	<b>69957,31</b>	<b>89236,83</b>	<b>21729,91</b>	<b>52,56</b>

\*) The data in columns 2 and 3 are determined at the DC voltage at the inverter output. The other data are measured at AC voltage, the inverters having an efficiency of approximately 97%.

The enterprise operates every day of the week, although activity is reduced during weekends. To determine the weekly operating pattern, the energy produced, consumed, and fed into the grid was calculated for each day of the week based on the recorded data (values summed for each day over the course of one year). The resulting values are presented in Table 2. The data in Table 2 highlight that activity remains essentially constant on weekdays, with the exception of weekend days. The analysis of the solar installation's production compared to the previous year highlights that its operation is consistent with the project specifications, with minor deviations caused by variations in solar activity (Figure. 4). The electrical energy purchased from the grid—which determines the enterprise's electricity bill and depends on both the company's activity and the energy produced by the solar installation—is shown comparatively for two consecutive years in (Figure 5). It can be observed that the implementation of the solar installation within the enterprise has led to a reduction of approximately 7% per year in the energy purchased from the public electricity grid, resulting in a corresponding decrease in the electricity bill. Furthermore, the economic analysis also accounts for the financial benefit obtained from selling the energy fed into the public supply grid.

Table 2. Data on the energy balance for the days of the week

Day	Energy produced by the solar installation [kWh]	PV energy used in the factory [kWh]	Energy purchased from the electrical grid [kWh]	Total energy used in the enterprise [kWh]	Energy fed into the electrical grid [kWh]
Monday	5827,60	2910,70	11717,60	14628,30	2891,06
Tuesday	6014,63	3004,17	10175,00	13179,17	2991,51
Wednesday	5889,00	3287,20	10132,80	13420,00	2543,44
Thursday	5275,00	3212,00	10775,00	13987,00	2052,51
Friday	6070,00	3232,00	11512,00	14744,00	2791,78
Saturday	6065,00	1247,00	7115,00	8362,00	4695,04
Sunday	6203,00	2388,00	8530,00	10918,00	3764,34
<b>Total</b>	<b>41344,23</b>	<b>19281,07</b>	<b>69957,40</b>	<b>89238,47</b>	<b>21729,68</b>

Considering that the purchase of the solar panels was subsidized through the government-supported program (Environmental Fund Agency), the cost of the energy they generate was determined solely by installation and operational expenses. This resulted in energy prices that are more advantageous than the cost of electricity supplied from the public grid

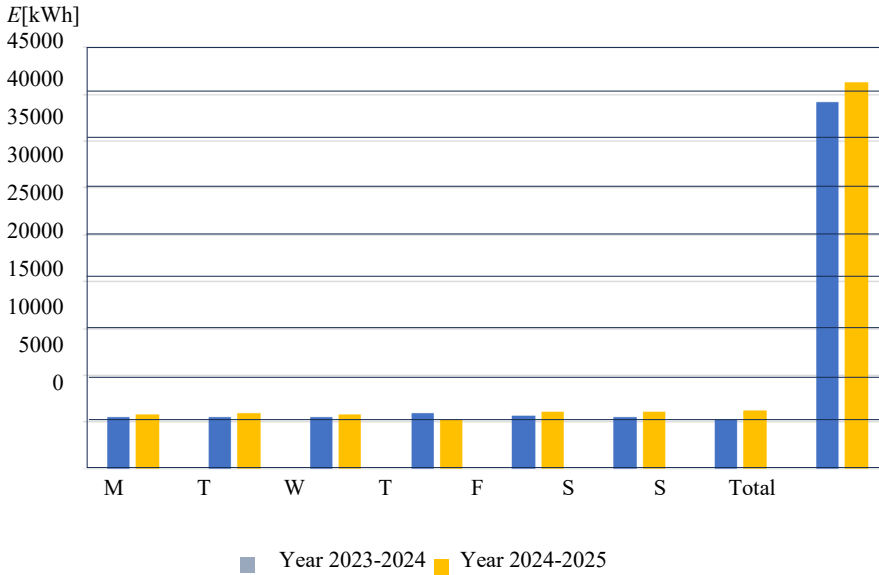

Fig. 4. Energy generated by the solar installation

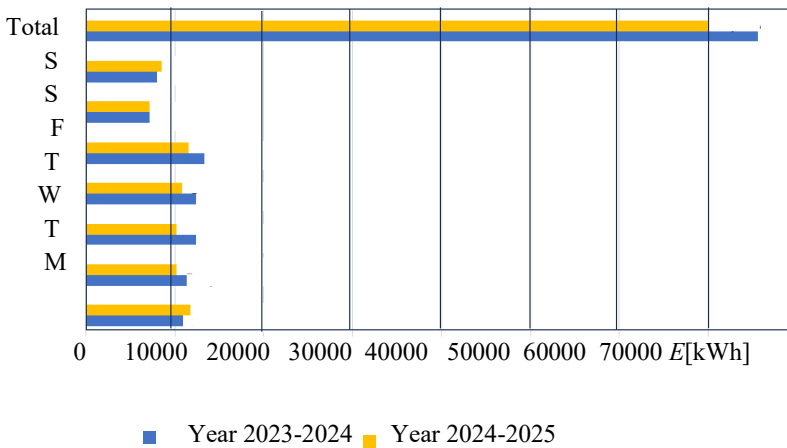

Fig. 5. Energy purchased from the electrical grid

#### 4. Tool for simulating the operation of the power supply solution

To obtain the data required for managing the power supply solution and for validating the measured data, a computational tool was developed using the MATLAB-Simulink platform. In this tool, the parameters of the photovoltaic panels are introduced, the solar irradiance level and the enterprise load profile are estimated, and the levels of energy production, the amount of solar energy used in the production process, the amount of energy to be drawn from the public electrical grid, and the amount of energy fed into this grid are determined. The DC electrical energy production is affected by the inverter efficiency, and the inverter's maximum nominal value is specified. This allows determining the available AC power in the alternating-voltage circuits. The program enables the calculation of the power generated by the solar panels and used directly in the technological process, the power fed into the public electrical grid, and the power drawn from the public grid when the solar source does not cover the required electrical energy.

##### Block Parameters Used in the Model

- **From Workspace – Ppv\_ts**  
*Input data:* Hourly vector of DC power produced by the PV panels, generated from monthly data.  
*Size:* 8784×1 (hours/year)
- **From Workspace – Pload\_ts**  
*Input data:* Hourly vector of power demanded by the consumers.  
*Size:* 8784×1
- **Constant – eta\_inv**  
*Value:* 0.97 (average inverter efficiency)
- **Constant – P\_inv\_max**  
*Value:* 37.5 kW (total nominal power of the two Fronius inverters: 17.5 + 20 kW)
- **Product**  
*Operation:* Multiplies Ppv\_ts by eta\_inv → resulting in P\_pv\_ac\_ideal
- **Saturation**  
*Function:* Limits the output power to the maximum inverter capacity (P\_inv\_max), ensuring that P\_pv\_ac\_ideal does not exceed 37.5 kW.  
 Lower limit = 0; Upper limit = P\_inv\_max

### Function of Each Block in the Energy Flow Model

#### Saturation

Function: Limits the available AC power to the inverter's maximum capacity.

Output:  $P_{pv\_ac}$

#### MinMax (set to MIN)

Inputs:  $P_{pv\_ac}$ ,  $P_{load}$ ; Output:  $P_{autocons}$  (directly self-consumed energy)

$Sum (P_{pv\_ac} - P_{load}) + Saturation [0, \infty]$ ; Output:  $P_{inject}$  (energy injected into the grid)

$Sum (P_{load} - P_{pv\_ac}) + Saturation [0, \infty]$ ; Output:  $P_{buy}$  (energy purchased from the grid)

**Gain (1/3600)** Role: Converts power from kW to kWh at each hourly time step (3600 seconds)

#### Discrete-Time Integrator

Sample time: 3600 s; Initial condition: 0

Outputs: Cumulative energy values over the simulation period:

#### To Workspace

Nume variabile:  $P_{pv\_ac\_sim}$ ,  $P_{autocons\_sim}$ ,  $P_{inject\_sim}$ ,  $P_{buy\_sim}$ ,  $E\_*$ .

Save format: Array.  $E_{pv\_dc}$  (DC energy produced by PV)

$E_{pv\_ac}$  (AC energy available after inverter);  $E_{autocons}$  (self-consumed energy);  $E_{inject}$  (energy injected into the grid).

To validate the proposed computational tool, the data obtained from the experimental study (**Real**) were taken and compared with the calculated data (**Sim**), (Figure 6).

Month	Real_Prod	Real_Self	Real_Buy	Real_Inject	Sim_Prod	Sim_Self	Sim_Buy	Sim_Inject
{'Aprilie' }	5094.4	1746.7	5870.1	3636.9	4941.6	1742.8	5874	3198.8
{'Mai' }	6550.6	1836.5	4745.8	5097.5	6350.8	1710.3	4872	4640.4
{'Iunie' }	6555.1	2037.7	4041.3	5205.5	6316.8	1627.6	4451.4	4689.2
{'Iulie' }	5799.4	2796.1	6230.5	3321.7	5625.5	2042.8	6983.8	3582.7
{'August' }	5332.4	2586.1	4695	3164.8	5172.4	1710	5571.1	3462.4
{'Septembrie' }	3062	1568.8	5719	1608	2970.1	1417.6	5870.1	1552.5
{'Octombrie' }	2104.6	1650.9	5793.9	446.46	2041.5	1212.7	6232	828.79
{'Noiembrie' }	883.13	802.97	7609.3	86.89	856.64	850.19	7562.1	6.4417
{'Decembrie' }	523.44	473.91	8803.3	54.22	507.74	507.74	8769.5	0
{'Ianuarie' }	1097.6	585.2	4645.8	143.14	1064.7	762.32	4468.7	302.39
{'Februarie' }	1582.8	1127.5	5644.1	336.06	1535.3	1025	5746.6	510.37
{'Martie' }	2757.8	2067.3	6159.3	750.28	2675	1441.8	6784.7	1233.2
=== Mean abs error % [Prod, Self, Buy, Inject] ===								
	3.0572	17.2372	5.8847	46.4464				
$E_{pv}$	$E_{self}$	$E_{inj}$	$E_{buy}$	$E_{load}$	SCR	SSR		
40058	16051	24007	73186	89237	0.40069	0.17987		

Fig. 6. Calculated results (**Sim**) compared with real data (**Real**).

The data in Figure 6 confirm that during the winter season the monthly energy production from the solar source drops below 2 MWh, which necessitates an increased share of energy purchased from the public grid. (At the bottom of Figure 6, values corresponding to the AC bus are indicated, taking into account an inverter efficiency of approximately 97%).

## 5. Conclusions

The use of solar sources in electrical power supply schemes does not represent a direct method of increasing energy efficiency, as it does not reduce consumption while maintaining the same level of services. However, it can improve the beneficiary's economic efficiency, thereby contributing to its sustainability [5,6]. Nevertheless, their integration into energy systems can produce indirect effects on overall performance, through the reduction of transmission losses, the utilization of energy at the point of consumption, and the incorporation into advanced intelligent energy management systems. The analysis carried out highlighted the potential of using solar energy sources to reduce a user's electricity bill. For the analyzed boundary, the billed electricity demand was reduced by approximately 60% compared to previous values. To increase electricity production from solar sources and to use the generated energy more efficiently, the following observations are made: During periods of snowfall and dust accumulation, careful cleaning of the panels is advised. This will improve their efficiency and prevent degradation [7].

- Monthly analysis of inverter reports is recommended to monitor operational parameters; The electric vehicle charging station should be configured according to the designed parameters.
- The EV charging station should be better managed (more intensively used).
- The company's energy management must ensure better coordination of the technological process with the production periods of the solar source.

Based on the analyzed data, it can be concluded that the project will generate significant benefits in terms of energy and economic efficiency, as well as social and environmental impact. The implementation of the project will substantially reduce electricity-related expenses.

## R E F E R E N C E S

- [1] \*\*\*Law no. 121/2014 on energy efficiency and the promotion of renewable energy sources for end-users, updated and amended by Law no. 160/2016
- [2] \*\*\*Standard content “Monitoring report on the functionality of the photovoltaic panel system and electric vehicle charging stations”
- [3] \*\*\*Guide for the development and analysis of energy balances – ANRE Decision no. 2123/23.09.2014
- [4] \*\*\*Law no. 123/2012 on electricity and natural gas, with subsequent amendments and completions
- [5] \*\*\*Energy audit; Standard SR-EN16247-1-2013; General requirements
- [6] \*\*\* Hermina Albert, Ștefan Gheorghe, Nicolae Golovanov, Luminița Elefterescu, Radu Porumb, Electric Energy Quality; Contributions, Results, Perspectives. Bucharest, Agir Publishing House, 2013
- [7] \*\*\* Golovanov N., Gheorghe St., Lungu I., Porumb R., Tristiu I., Smart Distribution Systems for Supplying Electricity Users. Agir Publishing House, 2024