

## A COMPARISON BETWEEN CENTRALIZED AND LOCAL COGENERATION IN TERMS OF ENVIRONMENTAL IMPACTS

### *O COMPARAȚIE ÎNTRE COGENERAREA CENTRALIZATĂ ȘI CEA LOCALĂ PRIN PRISMA IMPACTURILOR ASUPRA MEDIULUI ÎNCONJURĂTOR*

Ovidiu ȚUȚUIANU <sup>1</sup>

**Abstract:** "Cogeneration" is an efficient and environmentally friendly technology recommended by the EU. The paper presents, through examples from Romania, achievements regarding "high power cogeneration (HPCG)" and "low and medium power (LMPCG)" installations, respectively. Some technical-economic and ecological performances are given for comparison. Under the conditions of decentralization and decarbonising of energy production LMPCG can become a unique solution, or complementary / alternative to HPCG. Having a long theoretical and practical activity in the field, the author argues that the decision to choose the optimal solution for heat supply of any type of consumer must be made based on a complex technical-economic calculation to assess for each variant, including environmental aspects and the impacts (positive and negative), "internalized" in the costs of heat production from those sources.

**Keywords:** thermal energy/heat production, centralized heat supply systems, local heat supply systems, cogeneration, high power cogeneration, low and medium power cogeneration, environmental aspects, environmental impacts, renewable energy sources, pollutant emissions.

**Rezumat:** „Cogenerarea” este o tehnologie eficientă și ecologică recomandată de UE. Lucrarea prezintă prin exemple din România, realizări privind instalații de „cogenerare de mare putere (CGMP)” și respectiv „de mică și medie putere (CGMMP)”. Sunt date pentru comparație unele performanțe tehnico-economice și ecologice. În condițiile descentralizării și decarbonizării producției de energie, CGMMP poate deveni o soluție unică, ori complementară/alternativă la CGMP. Având o îndelungată activitate teoretică și practică în domeniu, autorul susține că decizia pentru alegerea soluției optime pentru alimentarea cu căldură a oricărui tip de consumator trebuie să fie luată pe baza unui calcul tehnico-economic complex care să

---

<sup>1</sup>Eng., Scientific Councilor within Romanian National Committee of the World Energy Council and at the Romanian Energy Institute, e-mail: ovidiu.tutuianu@gmail .com

*evalueze pentru fiecare variantă, inclusiv aspectele de mediu și impacturile (pozitive și negative) asupra mediului, „internalizate” în costurile de producție a căldurii din sursele respective.*

**Cuvinte cheie:** producție de energie termică/căldură, sisteme centralizate de alimentare cu căldură, sisteme locale de alimentare cu căldură, cogenerare, cogenerare de mare putere, cogenerare de mică și medie putere, aspecte de mediu, impacturi asupra mediului, surse regenerabile de energie, emisii de poluanți.

## 1. Introduction

In Romania, according to climatic conditions and the level of urban development, the supply of heat/thermal energy for heating buildings (homes or other destinations) and the preparation of hot water for domestic and sanitary purposes can be achieved through four solutions, namely:

- individual installations.
- centralized systems based on thermal power plants.
- low and medium power cogeneration systems - local.
- high power cogeneration systems - centralized.

The paper proposes a comparison in terms of environmental impacts only between “High power cogeneration” (HPCG) and “Low and medium power cogeneration” (LMPCG), solutions that are clearly ahead of the others in the action of significant decrease of all pollutant emissions, including decarbonization of electricity and heat sources.

## 2. From the history of cogeneration in Romania

The experience of introducing *cogeneration* (combined and simultaneous production of electricity and heat, which together with the transport of thermal agents at a distance was known as *district heating*) in our country has marked a number of positive results and many failures [1]. However, compared to the solution of separate production of electricity and heat, cogeneration has demonstrated important economic benefits (a reduction in fuel consumption by 32-34%) and environmental (emissions are directly proportional to fuel consumption).

Romania, after the 1960s and now is one of the main European countries that have benefited and still benefit (even if not at the level of potential!) from such advantages. Thus, only in 1900, the fuel economy due

to cogeneration had an energy equivalent of 92.8 PJ. The main ecological consequences of this economy have materialized in:

- reduction: of SO<sub>2</sub> emissions by approx. 25%, of NO<sub>x</sub> with approx. 7%, of dust with approx. 22% , of CO<sub>2</sub>, about 13%;
- avoiding the collection, transport, and storage of approx. 400 000 t slag and ash that would have involved additional costs and other negative impacts on the environment;
- reduction by 12-15% of the quantities of cooling water required in thermal power plants [2].

Despite the decrease in heat consumption recorded in recent years in the systems of centralized thermal energy supply (SCTES) with cogeneration plants (CGP), the CO<sub>2</sub> emissions avoided by the operation in cogeneration regime of the energy companies RENEL / CONEL, represented 5.1 million t in 1998 and 3.8 million t in 1999 [3].

### 3. Cogeneration today

Under current conditions, cogeneration is a "no regrets" technology that is also in the forefront of the European Union's energy portfolio. The combined and simultaneous production of electricity and heat (useful heat) in SCTES, leads to the following advantages:

- increasing fuel efficiency;
- reducing dependence on fuel imports;
- efficient use of local energy resources (waste, biomass, biogas, geothermal potential, etc.) for heating / cooling systems;
- strategic location of CGP in energy use points;
- increasing the stability of the transmission network by reducing distances, congestion and flattening consumption peaks, including through energy storage systems;
- capacity to couple with existing or designed technologies for a lot of applications in the industrial, commercial or residential sector;
- reducing environmental pollution by limiting emissions of air pollutants (including CO<sub>2</sub>), heat pollution on surface water and the amount of slag and ash produced and stored [4];

As demonstrated theoretically and practically by "The father of district heating in Romania" – Prof. eng. Ioan D. Stancescu, our country, due to the specific climatic conditions, the macroeconomic situation, and the available primary energy resources, has favorable conditions for the development of high and medium / low power cogeneration [1].

However, against the background of the political, social and economic changes that took place in the country after 1990 and beyond, the situation deteriorated continuously, so that at the level of 2007, SCTES represented only 31% of the total heat market, compared to 69% of individual sources [5].

The main environmental aspects that lead to negative impacts on the environment in the case of cogeneration are:

- **Direct aspects:**

- *Inputs:* fuel consumption; water consumption; electricity consumption; thermal energy consumption; occupied land area;
- *Outputs:* emissions of pollutants into the atmosphere (HC, CO, NO<sub>x</sub>, SO<sub>2</sub>, CO<sub>2</sub>, dust); noises and vibrations; waste; sewage and other toxic fluids.

- **Indirect aspects:** energy embedded in installations, equipment, constructions throughout the life cycle of the systems.

#### 4. High power cogeneration (HPCG)

According to a European classification [6], the terms: micro, mini, low, medium and high power, refer to the range of electrical power installed in cogeneration units. Based on this classification, Table 1 presents the use of cogeneration plants by the degree of centralization of heat supply, the mode of administration of the plants and the related categories of consumers.

Table 1. Cogeneration: magnitude and areas of use [7]

Cogeneration type	Electric power installed in CGP	Type of heat supply	Method of administration	Consumer category
Micro-generation	<50 kW <sub>e</sub> /pc	Individually	Private	Houses, shops schools, hospitals
Mini-generation	50-500 kW <sub>e</sub> /pc	Descentralized collective	Local cooperative/associations	Small consumer groups
Low cogeneration	500 kW <sub>e</sub> –1 MW <sub>e</sub> /pc	Descentralized	Local cooperative/companies	Small urban areas, tertiary consumers
Medium cogeneration	1 MW <sub>e</sub> /pc-12 MW <sub>e</sub> /CGP	Central	City Halls, Tourism/Health Services	Medium urban and rural areas, small industries
High cogeneration	> 12 MW <sub>e</sub> /CGP	Central	City Halls, Companies	Big cities, Industrial areas

High power cogeneration has developed quantitatively and continues to grow qualitatively in Europe especially in: Germany, the Netherlands, the Scandinavian countries, the former U.R.S.S. (now the Russian Federation), Poland, the Czech Republic and Slovakia.

Although in Romania, especially after the year 2000, cogeneration has experienced a significant decline, some high-performance installations have been made, such as Combined Cycle (Gas-Steam) Cogeneration Plants (CCCGP) Bucharest West and Petrom-Brazi.

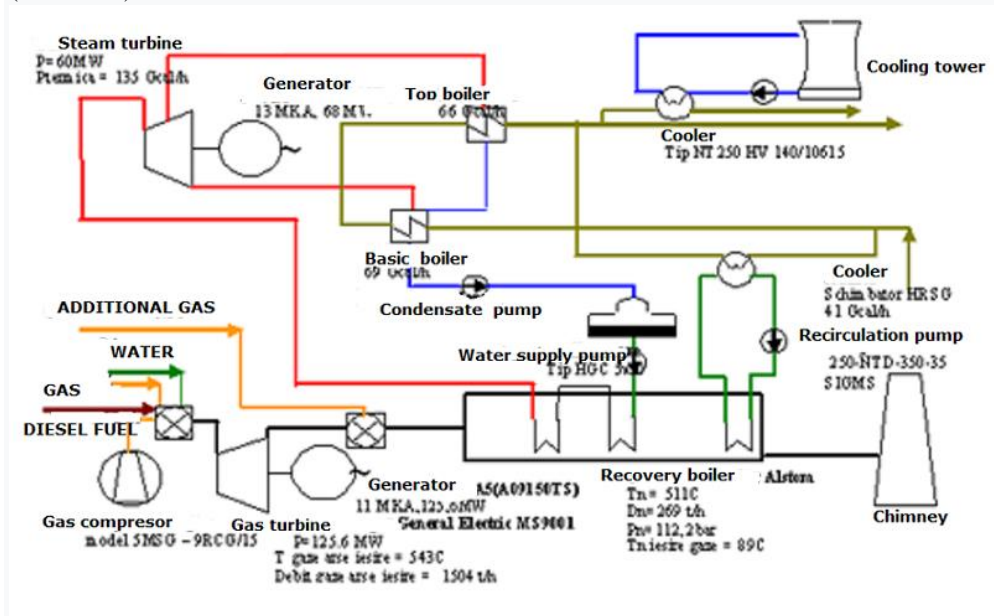

Figure 1. General thermal scheme of CCCGP Bucharest West [8]

On March 6, 2009 it was taken over in commercial operation by ELCEN Bucharest, CCCGP Bucharest West (figure 1). Performance parameters according to the project are:

- Gross electrical power = 197.71 MW;
- Net electric power = 187.93 MW;
- Specific fuel consumption = 2,056 kcal / kWh (8,566 kJ / kWh);
- Degree of fuel utilization (overall efficiency) = 85%;
- Maximum thermal load = 171.07 Gcal / h (199 MWt) [8].

Compared to conventional thermal power plants, the "combined cycle" from Bucharest West has low environmental impacts due to high global efficiency and lower emissions of pollutants into the atmosphere (Table 2).

Table 2. Pollutants emissions at CCCGP Bucharest West [8]

Pollutant	U.M.	At 60% of the maximum load of the gas turbine	At 100% of the maximum load of gas turbine
CO (corrected to 15% O <sub>2</sub> )	mg/ m <sup>3</sup> <sub>N</sub>	1,94 / 2,86*	18,72 / 2,63*
NO <sub>x</sub> expressed as NO <sub>2</sub> (corrected to 15% O <sub>2</sub> )	mg/ m <sup>3</sup> <sub>N</sub>	24,89 / 107,95*	26,78 / 107,1*
SO <sub>2</sub> (corrected to 15% O <sub>2</sub> )	mg/ m <sup>3</sup> <sub>N</sub>	1,15 / 38,51*	1,2 / 38,33*
Dust at 3% O <sub>2</sub> *	mg/ m <sup>3</sup> <sub>N</sub>	<3	<3

\*Only for Diesel operation

On August 1, 2012, OMV Petrom, the largest producer of crude oil and gas in Southeast Europe, put into operation in Brazi (Prahova County) its own power plant, representing the largest "greenfield" project in the energy field carried out in Romania in the last twenty years. years (530 million euros, the value of the investment).

The plant is based on a combined gas-steam cycle with cogeneration. The total electric power of 860 MW is installed in two gas turbines of 280 MW each and a steam turbine of 300 MW. The annual electricity production is estimated at 1.8 TWh, with a natural gas consumption of about 1.2 billion m<sup>3</sup>.

The installation has a much lower impact on the environment compared to a conventional coal-fired thermal power plant (CTPP), both due to the high cycle efficiency (57% compared to the average 30% average CTPP) and the natural gas combustion.

Thus, CO<sub>2</sub> emissions are at the level of 350 g / kWh, compared to 800 g / kWh, a value recorded in conventional lignite power plants. There is also a high flexibility in the operation of the installation, due to the short start-up time (half compared to a conventional power plant) and high charging speed, beneficial for National Electric Power System operation, given the increase in power installed in wind farms in approx. 3,000 MW over the next four years [9].

## 5. Low and Medium Power Cogeneration (LMPCG)

The LMPCG solution is a consequence of decentralized electricity generation. Consequently, the simultaneous supply of heat/cooling and of electricity will be influenced by the specific aspects of this mode of supply.

The following technologies can be used to apply that solution:

- *Technologies based on fossil fuels:*
  - internal combustion engines, Diesel or gas (ICE);
  - mini and micro gas turbines (MGT);
  - steam turbines (ST);
  - Stirling engines (SE);
  - fuel cells (FC);
  - combined cycles gas-steam (CCGS).
- *Technologies based on the use of renewable energy sources, or waste:*
  - biogas or biofuel internal combustion engines;
  - steam turbine installations, powered by boilers burning various types of biomass;
  - gas turbine installations, which use in the combustion chamber fuel products resulting from the gasification or pyrolysis of biomass.
- *Unconventional technologies:*
  - fuel cells.

According to some research, NO<sub>x</sub> emissions at MGT, comparable to those at ICE in 2005, were to reach much lower levels after 2020. The comparison presented in Table 3 highlights the fact that among the classic cogeneration technologies, SE produce the lowest pollutant emissions [5].

Table 3. Pollutant emissions for various technologies used at LMPCG [5]

Type of installation	Pollutant emissions [g / kWh]		
	Hydrocarbons (HC)	CO	NO <sub>x</sub>
CGP on coal	0.008	0.150	5.500
Gas turbines	0.300	0.700	2.700
ICE with stoichiometric burning	2.000-3.000	13.000-22.000	12.000-21.000
ICE with poor burning	1.300	4.000	2.700
ICE cu with catalytic converter	1.300	2.700	1.000
SE	0.005	0.007-0,600	0.200-0,700

Table 4 compares some environmental aspects related to LMPCG, such as: “*specific area occupied*”, “*noise level produced*”, as well as some “*technology available to control (reduce) pollutant emissions*”. Of course, an in-depth analysis of the environmental impacts produced by the

application of HPCG and LMPCG technologies must take into account all the environmental aspects (*direct* and *indirect*) associated with them. At first glance, compared to centralized production, local production can provide quality energy, with a higher degree of safety and more "environmentally friendly", with technological options of great diversity, but not enough technically and economically.

Table 4. Environmental aspects for technologies using LMPCG [10], [11]

Cogeneration technology	Specific surface occupied [m <sup>2</sup> / MW <sub>e</sub> ]	Noise level [dB]	Emissions of pollutants [g / kWh <sub>e</sub> ]	Available technology for emissions control
ICE with gas	13-28	80-100	NO <sub>x</sub> :0.7-42.0 CO:0.8-27.0	Soundproof enclosure; poor / very poor combustion and low temperature in combustion chamber
Diesel ICE	13-37	67-92	NO <sub>x</sub> :6.0-22.0 CO:1.0-8.0	Soundproof enclosure; poor combustion tracking system
ICE biofuel	9-19	67-92	NO <sub>x</sub> :2.0-12.0 CO:2.0-7.0	Fuel chamber on liquid fuel
Gas microturbine	19-46	<60	NO <sub>x</sub> :9.0-125.0 CO: 2.0-7.0 (ppm)	Container
Industrial gas turbine	4-93	67-92	NO <sub>x</sub> :25.0-200.0 CO:7.0-200.0 (ppm)	Container (sometimes); water / steam injection; DENO <sub>x</sub> installation
FC –with membrane	56-280	46	NO <sub>x</sub> :0.007 CO:0.01	No container
FC- with phosphoric acid	0-14	72	NO <sub>x</sub> :0.007 CO:0.01	Generally no container

Recently, some state or private consumers, with various profiles from many areas of Romania, have equipped their investments with medium and low power cogeneration plants.

Examples of LMPCG installations designed by a private company with equipment manufactured abroad put into operation in the period 2013-2016 are shown in Table 5.

From the experience so far, the respective facilities have fully demonstrated the advantages of cogeneration even on a small scale.

Table 5. LMPCG installations put into operation in Romania [12]

Installed powers [kW <sub>e</sub> /kW <sub>th</sub> ]	Powered consumer	Date of commissioning
20/40	<i>Dynamic Spa</i> – Caransebess	August 2013
66/142	<i>City Plaza Hotel</i> – Cluj/Napoca	September 2014
20/40	<i>"Gh.Asachi"</i> <i>Universithy</i> -Iassy	June 2015
50/90	<i>Grand Hotel</i> – Balvanyos	April 2016
2x20/40	<i>Tisa Hotel</i> – Olanessti	July 2016
33/72	<i>Salis Hotel</i> – Turda	October 2016

## 6. Conclusions

The supply of thermal energy for space heating and the preparation of hot water is, first of all, a vital element in ensuring the civilized living conditions, health and working capacity of the population.

Based on the existing quantitative experience in this field in Romania, it is imperative that local authorities establish the optimal solutions that are required, starting from specific detailed analyzes recommended by specialists including the author of the paper [13].

Technical and economic measures must be supported by legislative initiatives to enable and stimulate the payment of heating and hot water services.

With priority, the problem must be solved in the big urban agglomerations, starting with the country's capital, Bucharest, where the situation is approaching a real collapse!

If the mayors of the Capital research the history, they will see how their predecessors, through *the General Society of Gas and Electricity*, founded 115 years ago, set out to provide Bucharestians with electricity and synthetic, then natural, gas in good conditions and at affordable prices.

Of course, we should not forget and refine the experiences of supplying heat to various industries, agricultural and flower greenhouses, but also to consumers in rural areas.

Cogeneration, in general, and cogeneration of medium and low power, in particular, are technical-economic solutions recommended by the EU, especially in the conditions of market liberalization and continuous tightening of environmental protection regulations.

Decentralizing the production of thermal energy by bringing the generating source closer to the place of consumption reduces the investment

and losses in the thermal networks, ensuring the possibility of capitalizing on local renewable energy sources.

***Thus, LMPCG can become a unique solution, or complementary / alternative to HPCG,. especially in the case of Bucharest, where the heat supply was based mainly on high power cogeneration (with installations, now physically and morally used) and long thermal networks with even worse conditions.***

The decision to choose the optimal solution should be taken on the basis of a comparative technical-economic calculation of the feasible variants, using complex criteria such as "*updated total costs*" or "*heat production cost*". At least the "*duration of gross return on investment*" criterion could be used for feasibility studies. It is imperative that the criteria for comparing the heat supply solutions of consumers of all types take into account the environmental aspects and their impacts (*positive* and *negative*) throughout the „*life cycle of the installations*”, which must be "internalized" in the production costs of heat from those sources.

The criteria for comparing solutions in terms of environmental impact must take into account, in addition to the *emissions* of pollutants discharged into chimneys and *imissions* (concentrations of pollutants in the air, resulting from the dispersion of emissions, locally), which depend mainly on the volume of the exhaust gases and the height of the chimney and must be within the local limits set by the environmental authorities. In the case of localities where several LMPCG sources operate, the synergistic effect of all of them will be taken into account.

As at this time the heat supply of the population in the main localities of Romania is facing particularly serious problems, caused by the aging of the facilities and the poor maintenance especially of the thermal networks (which have unacceptable losses of thermal agents) a systemic approach is needed about complete technological chain: production, transport, distribution, consumption.

## BIBLIOGRAPHY

- [1] O.Țuțuianu „Profesorul Ioan D. Stăncescu-Părintele termoficării din România”. Editura AGIR, București, 2014. [ O.Tsutsuianu „Professor Ioan D. Stancescu-Father of district heating in Romania. AGIR Publishing House, Bucharest, 2014].
- [2] C.Moțoiu, O.Țuțuianu „Limitarea impactului asupra mediului înconjurător prin termoficare”. Raport IV.1 la Sesiunea științifică a Comisiei de energetică a Academiei Române, București, 16-17.12.1993. [ C.Motsoiu, O.Tsutsuianu „Limiting the impact

- on the environment by district heating". Report IV.1 at the Scientific Session of the Energy Commission of the Romanian Academy, Bucharest, 16-17 December 1993].
- [3] *O.Țuțuiianu* „Importanța ecologică a cogenerării”. Producerea, transportul și distribuția energiei electrice și termice, nr.3, martie, 2002, p.17-21. [O.Țuțuiianu "The ecological importance of cogeneration". Production, transport and distribution of electricity and heat, no. 3, March, 2002, pp.17-21].
- [4] *D.Coman, A.Leca*. „Dezvoltarea cogenerării – între opțiune și necesitate pentru creșterea eficienței energetice și reducerea emisiilor”. Mesagerul Energetic, Anul XII, Nr.127-128, mai-iunie 2012, p.25-31. [D.Coman, A, Leca. "Developing cogeneration - between option and need to increase energy efficiency and reduce emissions." The Energy Messenger, Year XII, No.127-128, May-June 2012, pp.25-31].
- [5] *V.Athanasovici, I.S.Dumitrescu, R.Pătrașcu, I.Bitir, E.Minciuc, Fl.Alexe, V.Cenușe, Cr.Răducanu, C.Coman.*, *Cr.Constantin* „Tratat de inginerie termică. Alimentări cu căldură. Cogenerare”. Editura AGIR, București, 2010. [V.Athanasovich, I.S.Dumitrescu, R.Patrashcu, I.Bitir, E.Minciuc, Fl.Alexe, V.Cenushe, Cr.Raducanu, C.Coman., Cr.Constantin „Treatise on thermal engineering. Heat supplies. Cogeneration”. AGIR Publishing House, Bucharest, 2010].
- [6] \*\*\* „Directiva 8/2004 a Parlamentului Consiliului European”. [„Directive 8/2004 of the European Parliament and of the Council” ].
- [7] *V.Athanasovici, Cr. Athanasovici* „Europa despre cogenerare și cogenerare de mică putere”. Energetica, vol.49, nr.7, 2001, p.316-321. [V.Athanasovich, Cr. Athanasovich "Europe on cogeneration and low-power cogeneration". Energetica, vol.49, nr.7, 2001, pp.316-321].
- [8] *O.Țuțuiianu, G.M.D.Poenaru, M.Voiculescu* „Evoluția turbinelor cu gaze în centralele electrice din București”. Energetica, vol.62, nr.7, 2014, p.272-277.[O.Țuțuiianu, G.M.D. Poenaru, M. Voiculescu "The evolution of gas turbines in power plants of Bucharest". Energetica, vol.62, nr.7, 2014, pp.272-277].
- [9] *M.Apostol* „OMV Petrom a inaugurat centrala electric de la Brazi”. Mesagerul Energetic Anul XII, nr.134, decembrie 2012, p.63-64.[M, Apostol "OMV Petrom inaugurated the Brazi power plant". Energetic Messenger Year XII, no.134, December 2012, pp.63-64].
- [10] \*\*\* „Assessment of distributed generation technology application”. Resources, Dynamics Corporation, Vienna, 2001.
- [11] \*\*\* „Distributed generation versus central generation”. Final report, EC/DG Research Contract ENG2-CT-2000-00441, august 2002.
- [12] *Gh.Țucu*, „Sisteme de cogenerare de înaltă eficiență pentru consumatori medii și mici”. [www.valeg.ro](http://www.valeg.ro). [Gh.Tsucu, "High efficiency cogeneration systems for medium and small consumers". [www.valeg.ro](http://www.valeg.ro)].
- [13] *O.Țuțuiianu*, „O analiză SWOT preliminară a Sistemelor de alimentare centralizată cu energie termică (SACET) din România”. În: *EMERG* 5, Anul III, 2017, p.126-138. [O.Tsutsuiianu, "A preliminary SWOT analysis of the Centralized Heat Supply Systems (CHSS) in Romania". In: *EMERG* 5, Year III, 2017, pp.126-138].